

(12) INTERNATIONAL APPLICATION PUBLISHED UNDER THE PATENT COOPERATION TREATY (PCT)

(19) World Intellectual Property Organization
International Bureau



INTERNATIONAL BUREAU OF PATENT COOPERATION
358, RUE DE LA FOUILLOE
CHAMBELEN, SUISSE

(43) International Publication Date
15 March 2001 (15.03.2001)

PCT

(10) International Publication Number
WO 01/18354 A1

- (51) International Patent Classification⁷: E21B 43/10 (74) Agent: MURGITROYD & COMPANY; 373 Scotland Street, Glasgow G5 8QA (GB).
- (21) International Application Number: PCT/GB00/03406 (81) Designated States (national): AE, AL, AM, AT, AU, AZ, BA, BB, BG, BR, BY, CA, CH, CN, CR, CU, CZ, DE, DK, DM, EE, ES, FI, GB, GD, GE, GH, GM, HR, HU, ID, IL, IN, IS, JP, KE, KG, KP, KR, KZ, LC, LK, LR, LS, LT, LU, LV, MA, MD, MG, MK, MN, MW, MX, NO, NZ, PL, PT, RO, RU, SD, SE, SG, SI, SK, SL, TJ, TM, TR, TT, TZ, UA, UG, US, UZ, VN, YU, ZA, ZW.
- (22) International Filing Date: 6 September 2000 (06.09.2000) (84) Designated States (regional): ARIPO patent (GH, GM, KE, LS, MW, MZ, SD, SL, SZ, TZ, UG, ZW), Eurasian patent (AM, AZ, BY, KG, KZ, MD, RU, TJ, TM), European patent (AT, BE, CH, CY, DE, DK, ES, FI, FR, GB, GR, IE, IT, LU, MC, NL, PT, SE), OAPI patent (BF, BJ, CF, CG, CI, CM, GA, GN, GW, ML, MR, NE, SN, TD, TG).
- (25) Filing Language: English
- (26) Publication Language: English
- (30) Priority Data: 9920935.5 6 September 1999 (06.09.1999) GB
- (71) Applicant (for all designated States except US): e2TECH LIMITED [GB/GB]; 47 Woodside Road, Bridge of Don, Aberdeen AB23 8EF (GB).
- (72) Inventor; and
- (75) Inventor/Applicant (for US only): OOSTERLING, Peter [NL/NL]; Noordeindseweg 128, NL-2651 CX Berkel en Rodenrijs (NL).
- Published:
— With international search report.
- For two-letter codes and other abbreviations, refer to the "Guidance Notes on Codes and Abbreviations" appearing at the beginning of each regular issue of the PCT Gazette.

(54) Title: APPARATUS FOR AND METHOD OF ANCHORING A FIRST CONDUIT TO A SECOND CONDUIT

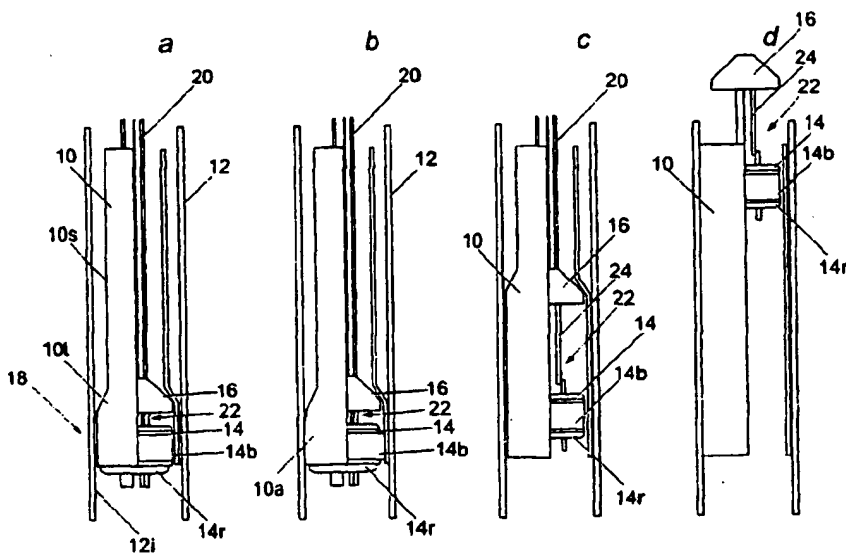

(57) Abstract: Apparatus and methods are disclosed for anchoring a first conduit (10) to a second conduit (12). The first conduit (10) is typically an expandable conduit whereby a portion of the first conduit is expanded by applying a radial force thereto to provide an anchor and/or seal between the first (10) and second (12) conduits. An inflatable device (14) is provided that can be used to provide a temporary anchor whilst the first (expandable) conduit (10) is radially expanded. An expander device (16) that is capable of applying a radial expansion force to the first conduit (10) is optionally attached to the inflatable device (14).



WO 01/18354 A1

1 **"Apparatus for and Method of Anchoring a First Conduit**
2 **to a Second Conduit"**

3

4 The present invention relates to an apparatus for and a
5 method of anchoring a first conduit to a second
6 conduit, the apparatus and method particularly, but not
7 exclusively, using an inflatable device to provide a
8 temporary anchor.

9

10 A borehole is conventionally drilled during the
11 recovery of hydrocarbons from a well, the borehole
12 typically being lined with a casing. Casings are
13 installed to prevent the formation around the borehole
14 from collapsing. In addition, casings prevent unwanted
15 fluids from the surrounding formation from flowing into
16 the borehole, and similarly, prevents fluids from
17 within the borehole escaping into the surrounding
18 formation.

19

1 Boreholes are conventionally drilled and cased in a
2 cascaded manner; that is, casing of the borehole begins
3 at the top of the well with a relatively large outer
4 diameter casing. Subsequent casing of a smaller
5 diameter is passed through the inner diameter of the
6 casing above, and thus the outer diameter of the
7 subsequent casing is limited by the inner diameter of
8 the preceding casing. Thus, the casings are cascaded
9 with the diameters of the casing lengths reducing as
10 the depth of the well increases. This gradual
11 reduction in diameter results in a relatively small
12 inside diameter casing near the bottom of the well that
13 could limit the amount of hydrocarbons that can be
14 recovered. In addition, the relatively large diameter
15 borehole at the top of the well involves increased
16 costs due to the large drill bits required, heavy
17 equipment for handling the larger casing, and increased
18 volumes of drill fluid that are required.

19

20 Each casing is typically cemented into place by filling
21 cement into an annulus created between the casing and
22 the surrounding formation. A thin slurry cement is
23 pumped down into the casing followed by a rubber plug
24 on top of the cement. Thereafter, drilling fluid is
25 pumped down the casing above the cement that is pushed
26 out of the bottom of the casing and into the annulus.
27 Pumping of drilling fluid is stopped when the plug
28 reaches the bottom of the casing and the wellbore must
29 be left, typically for several hours, whilst the cement
30 dries. This operation requires an increase in rig time
31 due to the cement pumping and hardening process, that
32 can substantially increase production costs.

1
2 It is known to use a pliable casing that can be
3 radially expanded so that an outer surface of the
4 casing contacts the formation around the borehole. The
5 pliable casing undergoes plastic deformation when
6 expanded, typically by passing an expander device, such
7 as a ceramic or steel cone or the like, through the
8 casing. The expander device is propelled along the
9 casing in a similar manner to a pipeline pig and may be
10 pushed (using fluid pressure for example) or pulled
11 (using drill pipe, rods, coiled tubing, a wireline or
12 the like).

13
14 Lengths of expandable casing are coupled together
15 (typically by threaded couplings) to produce a casing
16 string. The casing string is inserted into the
17 borehole in an unexpanded state and is subsequently
18 expanded using the expander device, typically using a
19 substantial force to facilitate the expansion process.
20 However, the unexpanded casing string requires to be
21 anchored either at or near an upper end or a lower end
22 thereof during the expansion process to prevent undue
23 movement. This is because when the casing string is in
24 an unexpanded state, an outer surface of the casing
25 string does not contact the surrounding borehole
26 formation or an inner face of a pre-installed casing or
27 liner (until at least a portion of the casing has been
28 radially expanded), and thus there is no inherent
29 initial anchoring point.

30

31 Slips are conventionally used to temporarily anchor the
32 unexpanded casing to the borehole during the expansion

1 process. Slips are generally wedge-shaped, steel,
2 hinged portion that provide a temporary anchor when
3 used. Slips are actuated whereby the wedge-shaped
4 portions engage with the surrounding borehole formation
5 or a casing or liner.

6
7 However, the mechanical configuration of slips often
8 causes damage to the casing or liner. In some cases,
9 the damage causes the slip to fail due to a loss of
10 mechanical grip. Slip-type devices in open-hole
11 engaging formation are often prone to slippage also.

12
13 According to a first aspect of the present invention,
14 there is provided an apparatus for anchoring a first
15 conduit to a second conduit, the apparatus comprising
16 an inflatable device for engaging with the first
17 conduit, wherein the inflatable device is inflatable to
18 facilitate anchoring of the first conduit to the second
19 conduit.

20
21 According to a second aspect of the present invention,
22 there is provided a method of anchoring a first conduit
23 to a second conduit, the method comprising the steps of
24 providing a first conduit, providing an inflatable
25 device in contact with the first conduit, running the
26 first conduit and inflatable device into the second
27 conduit, and subsequently inflating the inflatable
28 device to facilitate anchoring of the first conduit to
29 the second conduit.

30
31 According to a third aspect of the present invention,
32 there is provided a method of anchoring an expandable

1 conduit to a second conduit, the method comprising the
2 steps of providing an expandable conduit, running the
3 first conduit into the second conduit, passing an
4 inflatable device into the conduit, and subsequently
5 inflating the inflatable device to facilitate anchoring
6 of the expandable conduit to the second conduit.

7

8 The first conduit is typically an expandable conduit.

9

10 The first or expandable conduit may comprise any type
11 of expandable conduit that is capable of sustaining
12 plastic and/or elastic deformation. The first conduit
13 typically comprises an expandable liner, casing or the
14 like. The second conduit may comprise any type of
15 conduit. The second conduit typically comprises a
16 liner, casing, borehole or the like.

17

18 The inflatable device typically comprises an inflatable
19 balloon-type portion coupled to a ring. This allows a
20 string or the like to be passed through the inflatable
21 device in use.

22

23 Optionally, the inflatable device includes an expander
24 device. The expander device is optionally
25 telescopically coupled to the inflatable device, so
26 that when the expander device is moved a certain
27 distance, the inflatable device is deflated and
28 subsequently moves with the expander device.

29

30 Alternatively, the expandable device may be releasably
31 attached to the inflatable device, typically using a
32 latch mechanism.

1

2 The inflatable device may be located within the
3 expandable conduit. Alternatively, the inflatable
4 device may be coupled at or near an upper end of the
5 expandable conduit, or at or near a lower end of the
6 expandable conduit. The inflatable device may be
7 coupled to the expandable conduit using any suitable
8 connection.

9

10 The inflatable device is typically inflated to expand
11 the expandable conduit whereby the expandable conduit
12 contacts the second conduit, thereby providing an
13 anchor. In this embodiment, the expandable conduit is
14 optionally provided with a slotted portion to
15 facilitate expansion. This is advantageous as the
16 contact between the expandable conduit and the second
17 conduit provides the anchor, and forces applied to the
18 expandable conduit are mainly channelled into the
19 second conduit via the expandable conduit and not the
20 inflatable device.

21

22 Alternatively, the inflatable device is inflated
23 whereby a portion thereof directly contacts the second
24 conduit to provide an anchor.

25

26 The expander device is typically manufactured from
27 steel. Alternatively, the expander device may be
28 manufactured from ceramic, or a combination of steel
29 and ceramic. The expander device is optionally
30 flexible.

31

1 The expander device is optionally provided with at
2 least one seal. The seal typically comprises at least
3 one O-ring.

4
5 The method optionally comprises one, some or all of the
6 additional steps of inserting an expander device into
7 the expandable conduit, operating the expander device
8 to expand the expandable conduit, deflating the
9 inflatable device, and removing the expander device
10 and/or the inflatable device from the expandable
11 conduit and/or the second conduit.

12
13 The method optionally comprises one, some or all of the
14 additional steps of attaching an expander device to the
15 inflatable device, operating the expander device to
16 expand the expandable conduit, re-attaching the
17 expander device to the inflatable device, deflating the
18 inflatable device, and removing the expander device
19 and/or the inflatable device from the expandable
20 conduit and/or second conduit.

21
22 The expander device is typically operated by propelling
23 it through the expandable conduit using fluid pressure.
24 Alternatively, the expander device may be operated by
25 pigging it along the expandable conduit using a
26 conventional pig or tractor. The expander device may
27 also be operated by propelling it using a weight (from
28 the string for example), or may be pulling it through
29 the expandable conduit (e.g. using drill pipe, rods,
30 coiled tubing, a wireline or the like).

31

1 Optionally, the inflatable device may act as a seal
2 whereby fluid pressure can be applied below the seal.

3

4 Embodiments of the present invention shall now be
5 described, by way of example only, with reference to
6 the accompanying drawings, in which:-

7 Figs 1a to 1d are successive stages in anchoring
8 and expanding an expandable conduit within a
9 second conduit using a first embodiment of an
10 inflatable device;

11 Figs 2a to 2d are successive stages in anchoring
12 and expanding an expandable conduit within a
13 borehole to tie back the expandable conduit to a
14 casing using a second embodiment of an inflatable
15 device;

16 Figs 3a to 3d are successive stages in anchoring
17 and expanding an expandable conduit within a
18 second conduit using a third embodiment of an
19 inflatable device;

20 Fig. 4a is a front elevation showing a first
21 configuration of a friction and/or sealing
22 material that can be applied to an outer surface
23 of the conduits shown in Figs 1 to 3;

24 Fig. 4b is an end elevation of the friction and/or
25 sealing material of Fig. 4a;

26 Fig. 4c is an enlarged view of a portion of the
27 material of Figs 4a and 4b showing a profiled
28 outer surface;

29 Fig. 5 is a schematic cross-section of an
30 expandable conduit that can be used with the
31 present invention having an alternative

1 configuration of a friction and/or sealing
2 material;
3 Fig. 6a is an front elevation of the friction
4 and/or sealing material of Fig. 5; and
5 Fig. 6b is an end elevation of the friction and/or
6 sealing material of Fig. 6a.

7
8 Referring to Fig. 1, there is shown in sequence (Figs
9 1a to 1d) successive stages of anchoring an expandable
10 conduit 10 to a casing 12 provided in a borehole (not
11 shown), the borehole typically being drilled to
12 facilitate the recovery of hydrocarbons. The
13 expandable conduit 10 is typically an expandable liner
14 or casing, but any type of expandable conduit may be
15 used.

16
17 The borehole is conventionally lined with casing 12 to
18 prevent the formation around the borehole from
19 collapsing and also to prevent unwanted fluids from the
20 surrounding formation from flowing into the borehole,
21 and similarly, prevents fluids from within the borehole
22 escaping into the surrounding formation. It should be
23 noted that the casing 12 may comprise any type of
24 conduit, such as a pipeline, a liner, a casing, a
25 borehole or the like.

26
27 An inflatable device 14, that in this embodiment has an
28 expander device 16 telescopically attached thereto, is
29 positioned within the expandable conduit 10 before the
30 conduit 10 is inserted into the casing 12.

31

1 Referring to Fig. 1a, the conduit 10 with the
2 inflatable device 14 and expander device 16 located
3 therein is run into the hole to the required setting
4 depth. As can be seen in Fig. 1a, a lower end 10l of
5 the expandable conduit 10 is radially expanded
6 (indicated generally at 18) to allow the inflatable
7 device 14 and the expander device 16 to be located
8 therein. It will be appreciated that although Figs 1a
9 to 1d show the inflatable device 14 and expander device
10 16 located at or near the lower end 10l of the conduit
11 10, the inflatable device 14 and/or the expander device
12 16 may also be located at or near an upper end of the
13 conduit 10. In this case, the expander device 16 is
14 propelled downwardly using, for example, the weight of
15 a string, fluid pressure or any other conventional
16 method.

17
18 The inflatable device 14 may be of any suitable
19 configuration, but is typically a device that has an
20 inflatable annular balloon-type portion 14b that is
21 mounted on an annular ring 14r. The annular ring 14r
22 allows a string, wireline or the like to be passed
23 through the inflatable device 14 as required. This is
24 particularly advantageous where the inflatable device
25 14 is positioned at the upper end of the conduit 10.
26 Thus, substantially full-bore access is still possible.

27
28 Referring to Fig. 1b, the inflatable device 14 is
29 inflated to expand the inflatable annular balloon-type
30 portion 14b. As the balloon-type portion 14b expands,
31 an anchor portion 10a of the conduit 10 is also
32 expanded. The anchor portion 10a is expanded by the

1 inflatable device 14 until it contacts the casing 12,
2 as shown in Fig. 1b. This contact between the anchor
3 portion 10a of the expandable conduit 10 and casing 12
4 provides an anchor point and/or a seal between the
5 expandable conduit 10 and the casing 12. The outer
6 surface of the anchor portion 10a may be suitably
7 profiled (e.g. ribbed) or coated with a friction and/or
8 sealing material 100 (Figs 4a to 4c) to enhance the
9 grip of the conduit 10 on the casing 12. The friction
10 and/or sealing material 100 may comprise, for example,
11 any suitable type of rubber or other resilient
12 materials. It should be noted that the friction and/or
13 sealing material 100 can be provided on an outer
14 surface 10s of the conduit 10 at various axially
15 spaced-apart locations.

16
17 Referring to Figs 4a to 4c, the friction and/or sealing
18 material 100 typically comprises first and second bands
19 102, 104 that are axially spaced apart along a
20 longitudinal axis of the conduit 12. The first and
21 second bands 102, 104 are typically axially spaced by
22 some distance, for example 3 inches (approximately
23 76mm).

24
25 The first and second bands 102, 104 are preferably
26 annular bands that extend circumferentially around the
27 anchor point 10a of the conduit 10, although this
28 configuration is not essential. The first and second
29 bands 102, 104 typically comprise 1 inch wide
30 (approximately 25.4mm) bands of a first type of rubber.
31 The friction and/or sealing material 100 need not
32 extend around the full circumference of the conduit 10.

1
2 Located between the first and second bands 102, 104 is
3 a third band 106 of a second type of rubber. The third
4 band 106 preferably extends between the first and
5 second bands 102, 104 and is thus typically 3 inches
6 (approximately 76mm) wide.

7
8 The first and second bands 102, 104 are typically of a
9 first depth. The third band 106 is typically of a
10 second depth. The first depth is optionally larger
11 than the second depth, although they are typically the
12 same, as shown in Fig. 4a. The first and second bands
13 102, 104 may protrude further from the surface 10s than
14 the third band 106, although this is not essential.

15
16 The first type of rubber (i.e. first and second bands
17 102, 104) is preferably of a harder consistency than
18 the second type of rubber (i.e. third band 106). The
19 first type of rubber is typically 90 durometer rubber,
20 whereas the second type of rubber is typically 60
21 durometer rubber. Durometer is a conventional hardness
22 scale for rubber.

23
24 The particular properties of the rubber may be of any
25 suitable type and the hardnesses quoted are exemplary
26 only. It should also be noted that the relative
27 dimensions and spacings of the first, second and third
28 bands 102, 104, 106 are exemplary only and may be of
29 any suitable dimensions and spacing.

30
31 As can be seen from Fig. 4c in particular, an outer
32 face 106s of the third band 106 can be profiled. The

1 outer face 106s is ribbed to enhance the grip of the
2 third band 106 on an inner face 12i of the casing 12.
3 It will be appreciated that an outer surface on the
4 first and second bands 102, 104 may also be profiled
5 (e.g. ribbed).

6
7 The two outer bands 102, 104 being of a harder rubber
8 provide a relatively high temperature seal and a back-
9 up seal to the relatively softer rubber of the third
10 band 106. The third band 106 typically provides a
11 lower temperature seal.

12
13 Referring to Fig. 5, there is shown an alternative
14 conduit 120 that can be used in place of conduit 10.
15 Conduit 120 is substantially the same as conduit 10,
16 but is provided with a different configuration of
17 friction and/or sealing material 122 on an outer
18 surface 120s.

19
20 The expandable conduit 120 is provided with a pre-
21 expanded portion 120e in which an expander device (e.g.
22 expander device 16) and/or an inflatable device (e.g.
23 device 14) may be located whilst the conduit 120 is run
24 into a borehole or the like. It should be noted that
25 the expander device need not be located in the conduit
26 120 whilst it is being run into the borehole, and can
27 be located in the conduit 120 once it is in place.

28
29 As shown in Fig. 5, the expandable conduit 100 is
30 provided with the friction and/or sealing material 122
31 at at least one location. The friction and/or sealing
32 material 122 is applied to the outer surface 120s of

1 the conduit 120 at axially spaced apart locations,
2 typically spaced from one another by around 12 inches
3 (approximately 305mm).

4
5 The friction and/or sealing material 122 is best shown
6 in Figs 6a and 6b. The friction and/or sealing
7 material 122 is in the form of a zigzag. In this
8 embodiment, the friction and/or sealing material 122
9 comprises a single (preferably annular) band of rubber
10 that is, for example, of 90 durometers hardness and is
11 about 2.5 inches (approximately 28mm) wide by around
12 0.12 inches (approximately 3mm) deep.

13
14 To provide a zigzag pattern and hence increase the
15 strength of the grip and/or seal that the formation 150
16 provides in use, a number of slots 124a, 124b (e.g. 20)
17 are milled into the band of rubber. The slots 124a,
18 124b are typically in the order of 0.2 inches
19 (approximately 5mm) wide by around 2 inches
20 (approximately 50mm) long.

21
22 To create the zigzag pattern, the slots 124a are milled
23 at around 20 circumferentially spaced-apart locations,
24 with around 18° between each along one edge 122a of the
25 band. The process is then repeated by milling another
26 20 slots 124b on the other side 122b of the band, the
27 slots 124b on side 122b being circumferentially offset
28 by 9° from the slots 124a on the other side 122a.

29
30 In use, the friction and/or sealing material 122 is
31 applied to the outer surface 120s of the (unexpanded)
32 expandable conduit 120. It should be noted that the

1 configuration, number and spacing of the friction
2 and/or sealing material 122 can be chosen to suit the
3 particular application.

4

5 It should be noted that forces applied to the conduit
6 10, 120 e.g. by subsequent movement of the conduit 10,
7 120 that is by pushing or pulling on the conduit 10,
8 120 for example, will be mainly transferred to the
9 casing 12 via the anchor point and not through the
10 inflatable device 14. This is advantageous as it
11 reduces the risk of damage to the inflatable device 14.
12 Additionally, this also reduces the risk of damage to
13 the casing 12 that may have occurred where a
14 conventional slip is used. Also, conventional slips
15 may lose their grip on the casing 12 where damage
16 ensues or the casing 12 is weak. Transferring
17 substantially all of the forces directly to the casing
18 12 via the anchor point obviates these disadvantages.

19

20 The expander device 16 can then be pulled through the
21 expandable conduit 10, 120 to radially expand the
22 conduit 10, 120 as shown in Fig. 1c. The expander
23 device 16 can be propelled through the conduit 10, 120
24 in any conventional manner. In Fig. 1, the expander
25 device 16 is pulled through the conduit 10, 120 using a
26 string 20 that is attached to the expander device 16 in
27 any conventional manner.

28

29 In the embodiment shown in Fig. 1, the expander device
30 16 is telescopically coupled to the inflatable device
31 14 using a telescopic coupling, generally indicated at
32 22. Coupling 22 comprises one or more telescopically

1 coupled members 24 that are attached to the inflatable
2 device 14. As the expander device 16 is pulled
3 upwards, the telescopic coupling 22 extends a certain
4 distance, say 10 feet (approximately 3 metres), at
5 which point the telescopic member(s) 24 are fully
6 extended. At this point, the inflatable balloon-type
7 portion 14b is automatically deflated and further
8 upward movement of the expander device 16 causes the
9 inflatable device 14 also to move upward, as shown in
10 Fig. 1d.

11

12 It should be noted that the inflatable device 14 is no
13 longer required to anchor the conduit 10, 120 to the
14 casing 12 as the expanded conduit 10 (Figs 1c and 1d)
15 secure the (expanded and unexpanded) conduit 10, 120 to
16 the casing 12. The friction and/or sealing material
17 100, 122 is used to enhance the grip of the conduit 10,
18 120 on the casing 12 in use, and can also provide a
19 seal in an annulus created between the conduit 10, 120
20 and the casing 12.

21

22 The expander device 16 is continually pulled upwards
23 towards the surface until the expandable conduit 10,
24 120 is fully expanded to contact the casing 12.
25 Thereafter, the inflatable device 14 and the expander
26 device 16 may be removed from the expandable conduit
27 10, 120 and/or the casing 12 at the surface.

28

29 Anchoring and expanding the expandable conduit 10, 120
30 in this way has several advantages. With the
31 embodiment shown in Fig. 1, it is possible to deploy a
32 control line or coiled tubing to control operation of

1 the inflatable device 14 and any other apparatus
2 located in the borehole, and a control line, wireline
3 or coiled tubing may be used to propel or pull the
4 expander device 16. With the embodiment shown in Fig.
5 1, there is no pressure exposure to the surrounding
6 formation and no rig is required. With the inflatable
7 device 14 configured as an annular ring 14r,
8 substantially full bore access is still possible.

9
10 It should be noted that the method described with
11 reference to Fig. 1 is intended to expand the
12 expandable conduit 10, 120 in a single pass of the
13 expander device 16 through the expandable conduit 10,
14 120, but multiple passes and/or expansions are
15 possible.

16
17 Referring to Fig. 2, there is shown in sequence (Figs
18 2a to 2d) successive stages of hanging an expandable
19 conduit 30 off a casing 32 (ie tying back a liner), the
20 expandable conduit 30 typically comprising an
21 expandable liner and being used to line or case a lower
22 portion of a borehole 34, the borehole 34 typically
23 being drilled to facilitate the recovery of
24 hydrocarbons. The lower portion of the borehole 34 has
25 not been lined/cased, wherein the upper portion of the
26 borehole 34 has been lined with an existing casing or
27 liner 36.

28
29 In the embodiment shown in Fig. 2, the expandable
30 conduit 30 is provided with a friction and/or sealing
31 material 38 on an outer surface thereof. The function
32 of the friction and/or sealing material 38 is to

1 provide a (friction and/or sealing) coupling between
2 the expandable conduit 30 and the existing liner or
3 casing 36. The friction and/or sealing material 38 may
4 also provide a seal between the lower (unlined) and
5 upper (lined) portions of the borehole 34. The
6 friction and/or sealing material may comprise, for
7 example, any suitable type of rubber or other resilient
8 materials. For example, the friction and/or sealing
9 material 38 can be configured in a similar way to the
10 friction and/or sealing material 100, 122 described
11 above with reference to Figs 4 to 6.

12

13 Additionally, the conduit 30 may be provided with
14 friction and/or sealing material (e.g. material 100,
15 122) at a lower end 301 of the conduit 30 to enhance
16 the anchoring effect at this portion of the conduit.
17 Additionally, the friction and/or sealing material can
18 be provided at various spaced-apart locations along the
19 length of the conduit 30 to enhance the coupling
20 between the conduit 30 and the borehole 34 or casing
21 36.

22

23 Referring to Fig. 2, an inflatable device 40, that has
24 an expander device 42 releasably attached thereto, is
25 positioned within the expandable conduit 30 before the
26 conduit 30 is inserted into the borehole 34. The
27 conduit 30 is provided with an expandable portion of
28 casing or liner 44, portion 44 being provided with a
29 plurality of longitudinal slots 48. The portion 44 may
30 be located at a lower end 301 of the conduit 30 or may
31 be integral therewith.

1 Referring to Fig. 2a, the conduit 30 with the
2 inflatable device 40 and expander device 42 releasably
3 attached at or near a lower end thereof, is run into
4 the borehole 34 to the required setting depth. As can
5 be seen in Fig. 2a, a lower end 30l of the conduit 30
6 is radially expanded (indicated generally at 50) to
7 allow the expander device 42 to be located therein. It
8 will be appreciated that although Figs 2a to 2d show
9 the inflatable device 40 and expander device 42 located
10 at or near the lower end 30l of the conduit 30, the
11 inflatable device 40 and/or the expander device 42 may
12 also be located at or near an upper end of the conduit
13 30. In this case, the expander device 42 is propelled
14 downwardly using, for example, the weight of a string,
15 fluid pressure or any other conventional method.

16
17 The inflatable device 40 may be of any suitable
18 configuration, but is typically a device that has an
19 inflatable annular balloon-type portion 40b that is
20 mounted on an annular ring 40r. The annular ring 40r
21 allows a string, wireline or the like to be passed
22 through the inflatable device 40 as required. This is
23 particularly advantageous where the inflatable device
24 40 is positioned at the upper end of the conduit 30.

25
26 Referring to Fig. 2b, the inflatable device 40 is
27 inflated to expand the inflatable annular balloon-type
28 portion 40b. As the balloon-type portion 40b expands,
29 the expandable portion 44 of conduit 30 also expands.
30 As can be seen in Fig. 2b, the longitudinal slots 48
31 widen as the portion 44 expands. Portion 44 acts as an
32 anchor for the casing 30 and is expanded until it

1 contacts the borehole 34, as shown in Fig. 2b. This
2 contact between portion 44 and the borehole 34 provides
3 an anchor point and/or a seal between the expandable
4 conduit 30 (to which portion 44 is attached or integral
5 therewith) and the borehole 34.

6
7 As with the previous embodiment, the expander device 42
8 is then pulled through the expandable conduit 30 to
9 radially expand the conduit 30, as shown in Fig. 2c.
10 The expander device 42 can be propelled through the
11 conduit 30 in any conventional manner. In Fig. 2, the
12 expander device 42 is pulled through the conduit 30
13 using a drill pipe or string 52 that is attached to the
14 expander device 42 in any conventional manner.

15
16 As the expander device 42 is pulled upwards, the upward
17 movement thereof is stopped after a predetermined time
18 or distance, at which point the expander device 42 is
19 lowered until a coupling between the expander device 42
20 and the inflatable device 40 latches. As with the
21 previous embodiments, the inflatable annular balloon-
22 type portion 40b is automatically deflated and further
23 upward movement of the expander device 42 causes the
24 inflatable device 40 also to move upward, as shown in
25 Fig. 2d. It should be noted that the upward movement
26 of the expander device 42 should only be stopped once a
27 sufficient length of conduit 30 has been expanded to
28 provide a sufficient anchor.

29
30 It should also be noted that the portion 44 is no
31 longer required to anchor the conduit 30 to the
32 borehole 34 as the expanded conduit 30 (Figs 2c and 2d)

1 secures the conduit 30 to the borehole 34. The
2 friction and/or sealing material (where used) can help
3 to provide a reliable anchor for the conduit 30 whilst
4 it is being expanded and also when in use.

5
6 The expander device 42 is continually pulled upwards
7 until the conduit 30 is fully expanded, as shown in
8 Fig. 2d. Thereafter, the inflatable device 40 and the
9 expander device 42 may be removed from the expandable
10 conduit 30 and the borehole at the surface. As shown
11 in Fig. 2d, the conduit 30 expands whereby the friction
12 and/or sealing material 38 contacts the casing 36.
13 This provides a tie back to the casing 36 and
14 optionally a seal between the upper (lined) portion of
15 the wellbore and the lower (lined) borehole 34,
16 depending upon the composition of the material 38.

17
18 With the embodiment shown in Fig. 2, there is no
19 pressure exposure to the formation, full bore access is
20 still possible, the conduit 30 may be expanded in a
21 single pass (multiple passes possible) and it may be
22 used to anchor and set in an open hole. Additionally,
23 it provides a tie back to the casing 36 in a single
24 pass of the expander device 42. It should be noted
25 that the method described with reference to Fig. 2 is
26 intended to tie back the casing in a single pass, but
27 multiple passes and/or expansions are possible.

28
29 It should also be noted that successive lengths of
30 expandable conduit may be coupled to casings or liners
31 thereabove using the same method. Thus, the method(s)

1 described herein may be used to line or case a borehole
2 without the use of cement.

3

4 Referring to Fig. 3, there is shown in sequence (Figs
5 3a to 3d) successive stages of anchoring an expandable
6 conduit 80 to a casing 82 provided in a borehole (not
7 shown), the borehole typically being drilled to
8 facilitate the recovery of hydrocarbons.

9

10 An inflatable device 84 is releasably attached to a
11 lower end 801 of the expandable conduit 80 before the
12 conduit 80 is inserted into the casing 82. The
13 expander device 86 is located within the lower end 801
14 of the conduit 80, the lower end 801 being expanded to
15 accommodate the expander device 86. Similar to the
16 previous embodiment, the inflatable device 84 has the
17 expander device 86 releasably coupled thereto via a
18 coupling 88. Otherwise, the inflatable device 84 and
19 the expander device 86 are substantially the same as
20 the previous embodiments.

21

22 Referring to Fig. 3a, the casing 80 with the inflatable
23 device 84 attached thereto and the expander device 86
24 located therein is run into the hole to the required
25 setting depth. It will be appreciated that although
26 Figs 3a to 3d show the inflatable device 84 releasably
27 attached to the lower end 801 of the conduit 80, the
28 inflatable device 84 may be releasably attached at or
29 near an upper end of the conduit 80.

30

31 The inflatable device 84 may be of any suitable
32 configuration, but is typically a device that has an

1 inflatable annular balloon-type portion 84b that is
2 mounted on an annular ring 84r. The annular ring 84r
3 allows a string, wireline or the like to be passed
4 through the inflatable device 84 as required. This is
5 particularly advantageous where the inflatable device
6 84 and/or the expander device 86 are positioned at the
7 upper end of the conduit 80.

8
9 Referring to Fig. 3b, the inflatable device 84 is
10 inflated to expand the inflatable annular balloon-type
11 portion 84b. As the balloon-type portion 84b expands,
12 it contacts the casing 82, thus providing an anchor
13 between the conduit 80 and the casing 82. This contact
14 between the balloon-type portion 84b and the casing 82
15 provides an anchor point and/or a seal between the
16 conduit 80 and the casing 82.

17
18 It should be noted that in this embodiment, the forces
19 applied to the conduit 80 by subsequent movement of the
20 conduit 80, that is by pushing or pulling on the
21 conduit 80 for example, will be transferred to the
22 casing 82 via the inflatable device 84. However,
23 unlike conventional slips, the inflated balloon-type
24 portion 84b is less likely to damage the casing.
25 Additionally, the size of the balloon-type portion 84b
26 can be chosen whereby it is sufficiently large so as
27 not to lose its grip on the casing 82, even when the
28 inflatable device 84 is moved upwardly or downwardly.

29
30 The expander device 86 is pulled through the expandable
31 conduit 80 to radially expand the conduit 80, as shown
32 in Fig. 3c. The expander device 86 can be propelled

1 through the conduit 80 in any conventional manner, as
2 with the previous embodiments.

3

4 Also, and as with the previous embodiments, an outer
5 surface 80s of the conduit 80 can be provided with a
6 friction and/or sealing material. The friction and/or
7 sealing material may comprise, for example, any
8 suitable type of rubber or other resilient materials.
9 For example, the friction and/or sealing material can
10 be configured in a similar way to the friction and/or
11 sealing material 100, 122 described above with
12 reference to Figs 4 to 6.

13

14 Additionally, the conduit 80 may be provided with
15 friction and/or sealing material (e.g. material 100,
16 122) at a lower end 80l of the conduit 80 to enhance
17 the anchoring effect at this portion of the conduit 80.
18 Additionally, the friction and/or sealing material can
19 be provided at various spaced-apart locations along the
20 length of the conduit 80 to enhance the coupling
21 between the conduit 80 and the casing 82.

22

23 As the expander device 86 is pulled upwards, the upward
24 movement thereof is stopped after a predetermined time
25 or distance, at which point the expander device 84 is
26 lowered until the coupling 88 between the expander
27 device 86 and the inflatable device 86 latches. As
28 with the previous embodiments, the inflatable balloon-
29 type portion 84b is automatically deflated and further
30 upward movement of the expander device 86 causes the
31 inflatable device 84 also to move upward, as shown in
32 Fig. 3d. It should be noted that the upward movement

1 of the expander device 86 should only be stopped once a
2 sufficient length of conduit 80 has been expanded to
3 provide a sufficient anchor.

4
5 The expander device 86 is continually pulled upwards
6 towards the surface until the conduit 80 is fully
7 expanded to contact the casing 82. Thereafter, the
8 inflatable device 84 and the expander device 86 may be
9 removed from the borehole at the surface.

10
11 Anchoring and expanding the conduit 80 in this way has
12 the same advantages as in the previous embodiment, but
13 the Fig. 3 embodiment is designed to anchor and set in
14 cased hole rather than open hole.

15
16 The method and apparatus described herein may be used
17 for a plurality of different downhole functions
18 relating to the use of expandable conduit. For
19 example, they may be used where the original liner or
20 casing requires to be repaired due to damage or the
21 like by overlaying the damaged portion with a portion
22 of expandable conduit. They may also be used to tie
23 back to the liner or casing, as described herein.

24
25 Thus, there is provided in certain embodiments an
26 apparatus and method of anchoring an expandable conduit
27 to a second conduit. The apparatus and method of
28 certain embodiments provide numerous advantages over
29 conventional mechanical anchoring devices, such as
30 slips, particularly by reducing the potential damage to
31 conduits that mechanical slips may cause. Certain
32 embodiments of apparatus and methods involve the use of

1 an inflatable device that can either be a) attached
2 directly at or near the top or bottom of the expandable
3 conduit, or b) placed within the top or bottom of the
4 expandable conduit. In a), anchoring forces are
5 generated as a result of friction between the
6 inflatable device and the second conduit, the forces
7 being passed into the conduit via the inflatable
8 device. In b), anchoring forces are generated by
9 friction between an outer surface of the expandable
10 conduit and the second conduit, the forces being
11 substantially passed into the second conduit directly
12 via the expandable conduit. The outer surface of the
13 expandable conduit may be suitably prepared (ie
14 provided with a friction enhancing material) to
15 increase the strength of the anchor.

16

17 Modifications and improvements may be made to the
18 foregoing without departing from the scope of the
19 present invention.

1 CLAIMS

2 1. Apparatus for anchoring a first conduit to a
3 second conduit, the apparatus comprising an inflatable
4 device for engaging with the first conduit, wherein the
5 inflatable device is inflatable to facilitate anchoring
6 of the first conduit to the second conduit.

7

8 2. Apparatus according to claim 1, wherein the first
9 conduit is an expandable conduit.

10

11 3. Apparatus according to claim 1 or claim 2, wherein
12 the first conduit comprises any type of expandable
13 conduit that is capable of sustaining plastic and/or
14 elastic deformation.

15

16 4. Apparatus according to any preceding claim,
17 wherein the first conduit comprises an expandable
18 liner, casing or the like.

19

20 5. Apparatus according to any preceding claim,
21 wherein the second conduit comprises a liner, casing,
22 borehole or the like.

23

24 6. Apparatus according to any preceding claim,
25 wherein the inflatable device comprises an inflatable
26 balloon-type portion coupled to a ring.

27

28 7. Apparatus according to any preceding claim,
29 wherein the inflatable device includes an expander
30 device.

31

1 8. Apparatus according to claim 7, wherein the
2 expander device is telescopically coupled to the
3 inflatable device, so that when the expander device is
4 moved a certain distance, the inflatable device is
5 deflated and subsequently moves with the expander
6 device.

7

8 9. Apparatus according to claim 7, wherein the
9 expander device is releasably attached to the
10 inflatable device.

11

12 10. Apparatus according to claim 9, wherein the
13 expander device is releasably attached to the
14 inflatable device using a latch mechanism.

15

16 11. Apparatus according to any preceding claim,
17 wherein the inflatable device is located within the
18 expandable conduit.

19

20 12. Apparatus according to any one of claims 1 to 11,
21 wherein the inflatable device is coupled at or near an
22 upper end of the expandable conduit, or at or near a
23 lower end of the expandable conduit.

24

25 13. Apparatus according to any preceding claim
26 wherein the inflatable device is inflated to expand the
27 expandable conduit whereby the expandable conduit
28 contacts the second conduit, thereby providing an
29 anchor.

30

1 14. Apparatus according to claim 13, wherein the
2 expandable conduit is provided with a slotted portion
3 to facilitate expansion.

4

5 15. Apparatus according to any one of claims 1 to 12,
6 wherein the inflatable device is inflated whereby a
7 portion thereof directly contacts the second conduit to
8 provide an anchor.

9

10 16. A method of anchoring a first conduit to a second
11 conduit, the method comprising the steps of providing a
12 first conduit, providing an inflatable device in
13 contact with the first conduit, running the first
14 conduit and inflatable device into the second conduit,
15 and subsequently inflating the inflatable device to
16 facilitate anchoring of the first conduit to the second
17 conduit.

18

19 17. A method of anchoring an expandable conduit to a
20 second conduit, the method comprising the steps of
21 providing an expandable conduit, running the first
22 conduit into the second conduit, passing an inflatable
23 device into the conduit, and subsequently inflating the
24 inflatable device to facilitate anchoring of the
25 expandable conduit to the second conduit.

26

27 18. A method according to claim 16 or claim 17,
28 wherein the method includes one, some or all of the
29 additional steps of inserting an expander device into
30 the expandable conduit, operating the expander device
31 to expand the expandable conduit, deflating the
32 inflatable device, and removing the expander device

1 and/or the inflatable device from the expandable
2 conduit and/or the second conduit.

3

4 19. A method according to any one of claims 16 to 18,
5 wherein the method includes one, some or all of the
6 additional steps of attaching an expander device to the
7 inflatable device, operating the expander device to
8 expand the expandable conduit, re-attaching the
9 expander device to the inflatable device, deflating the
10 inflatable device, and removing the expander device
11 and/or the inflatable device from the expandable
12 conduit and/or second conduit.

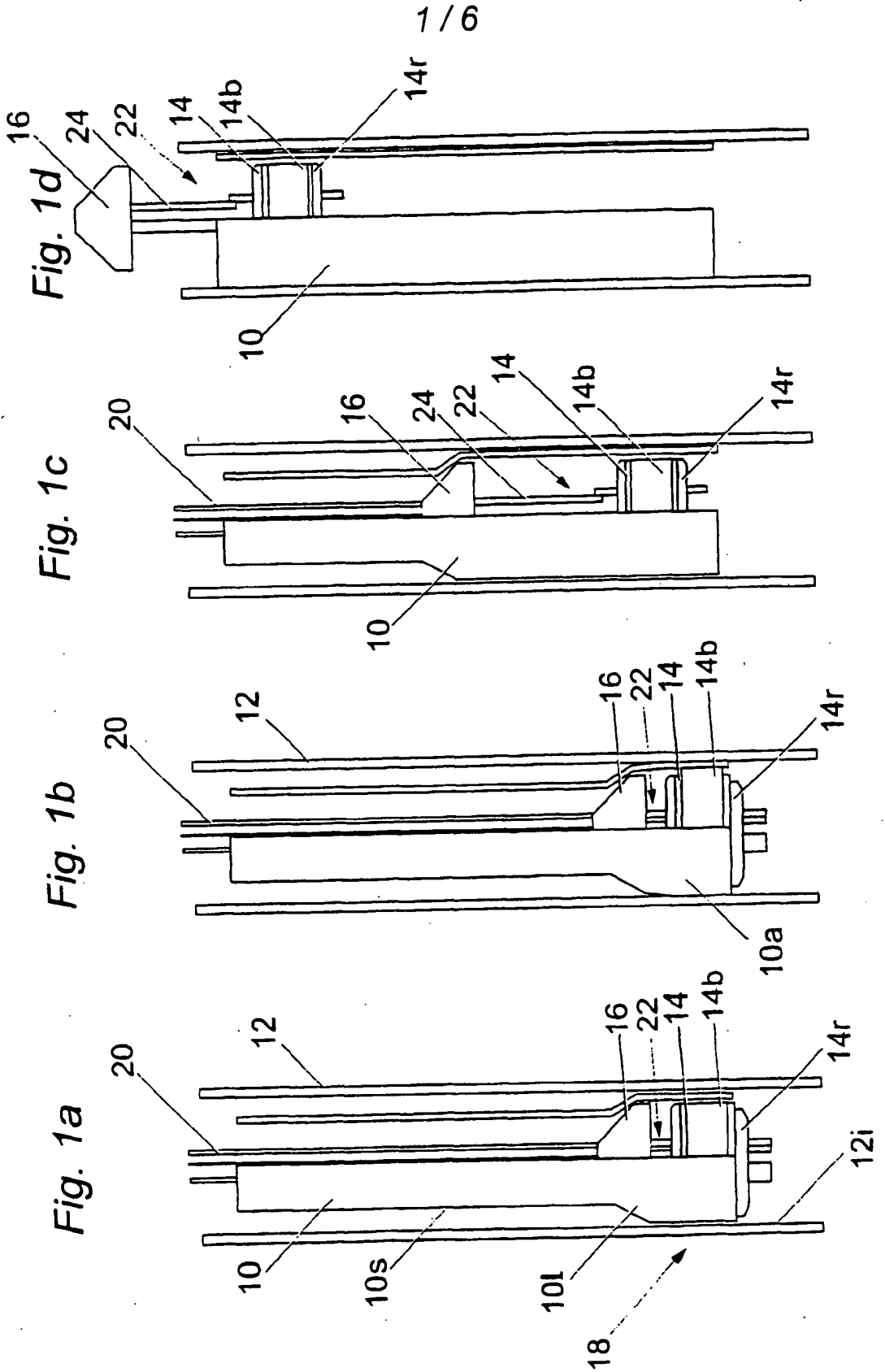

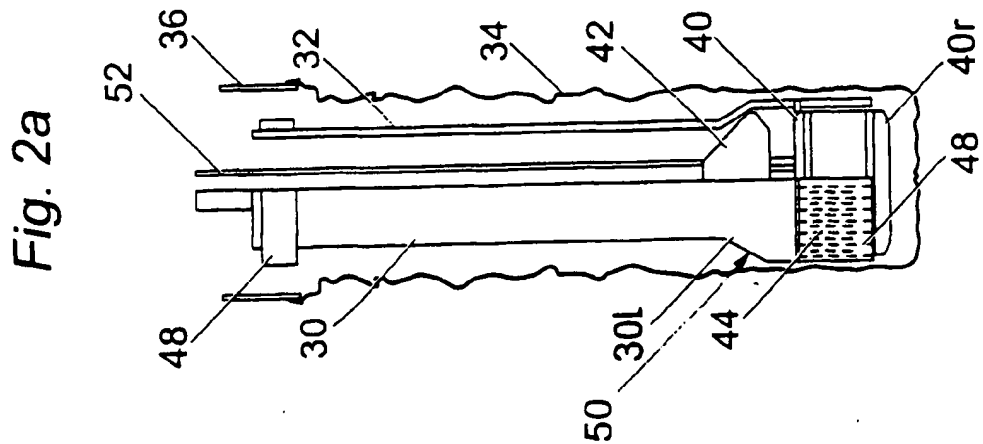
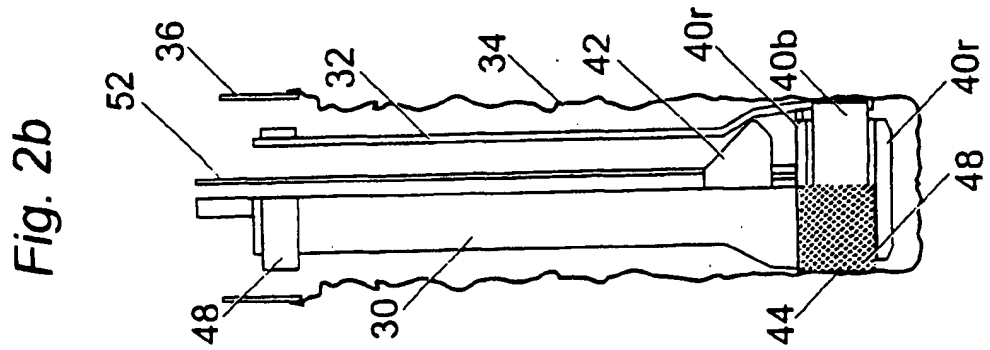
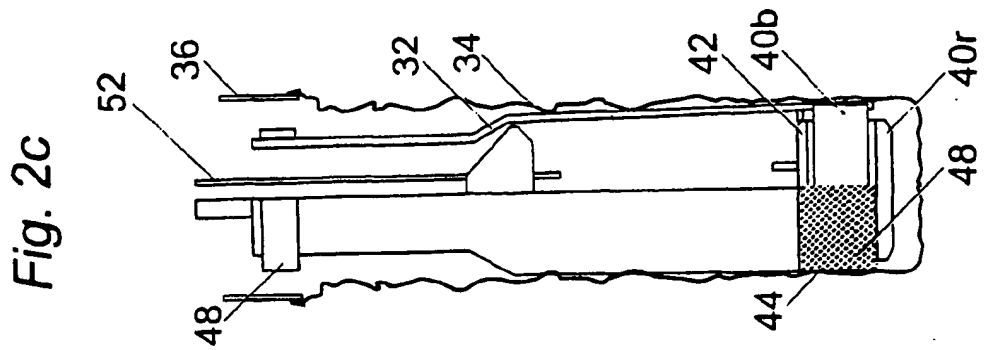
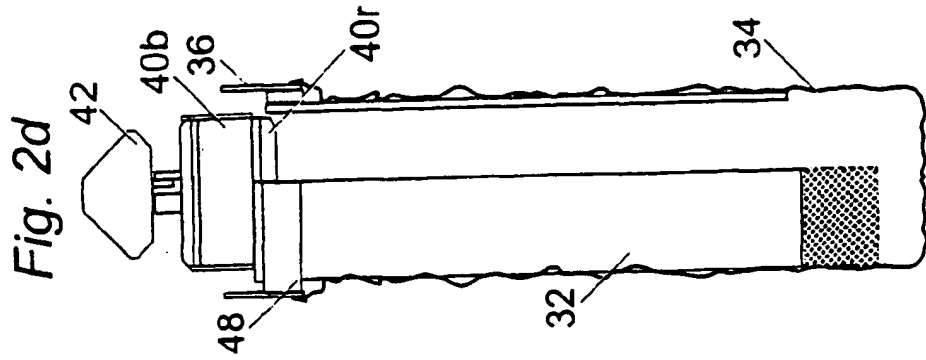

3/6

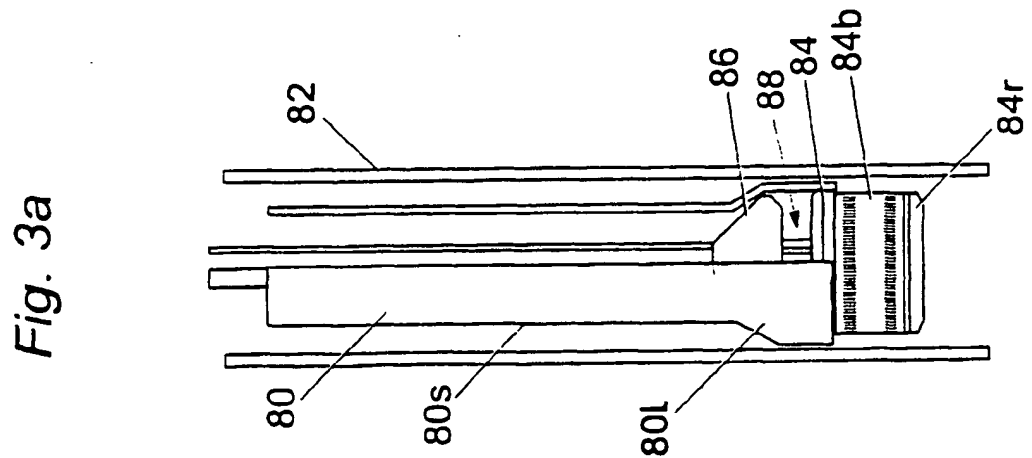
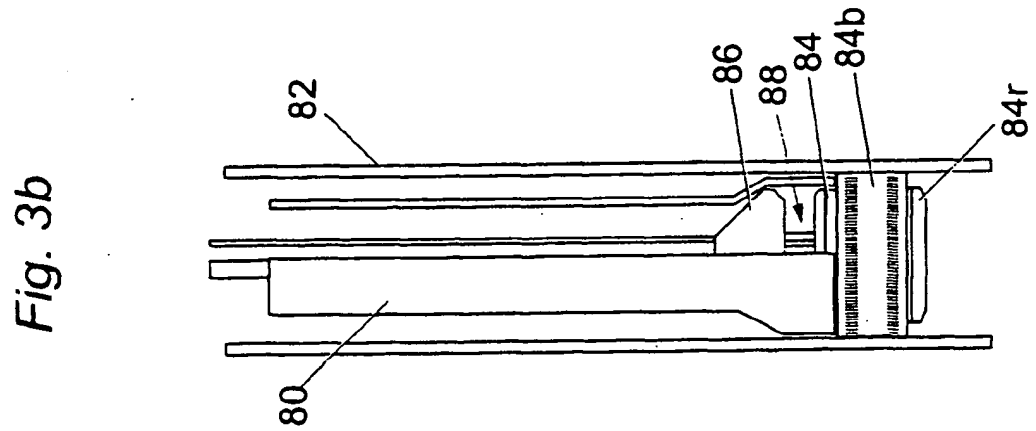
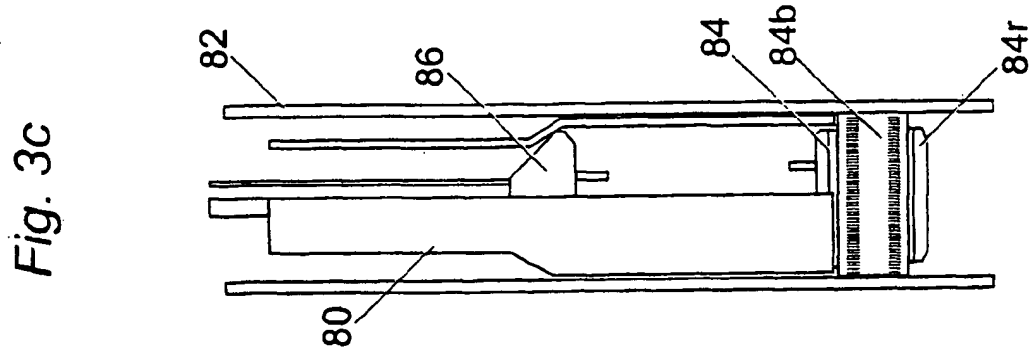
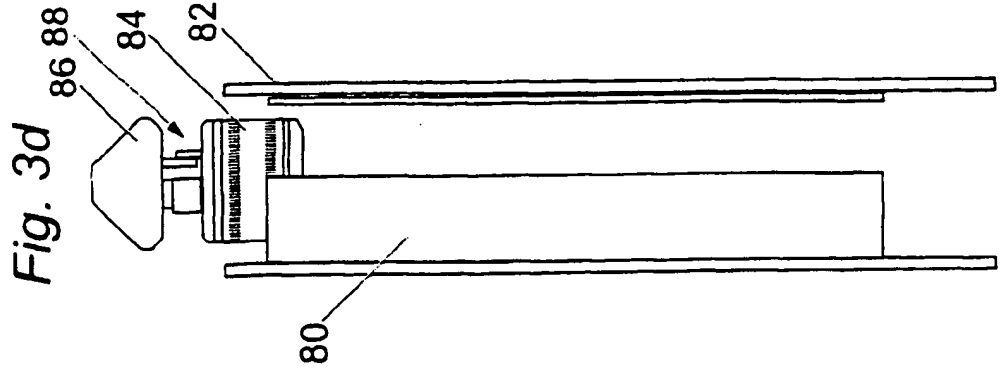

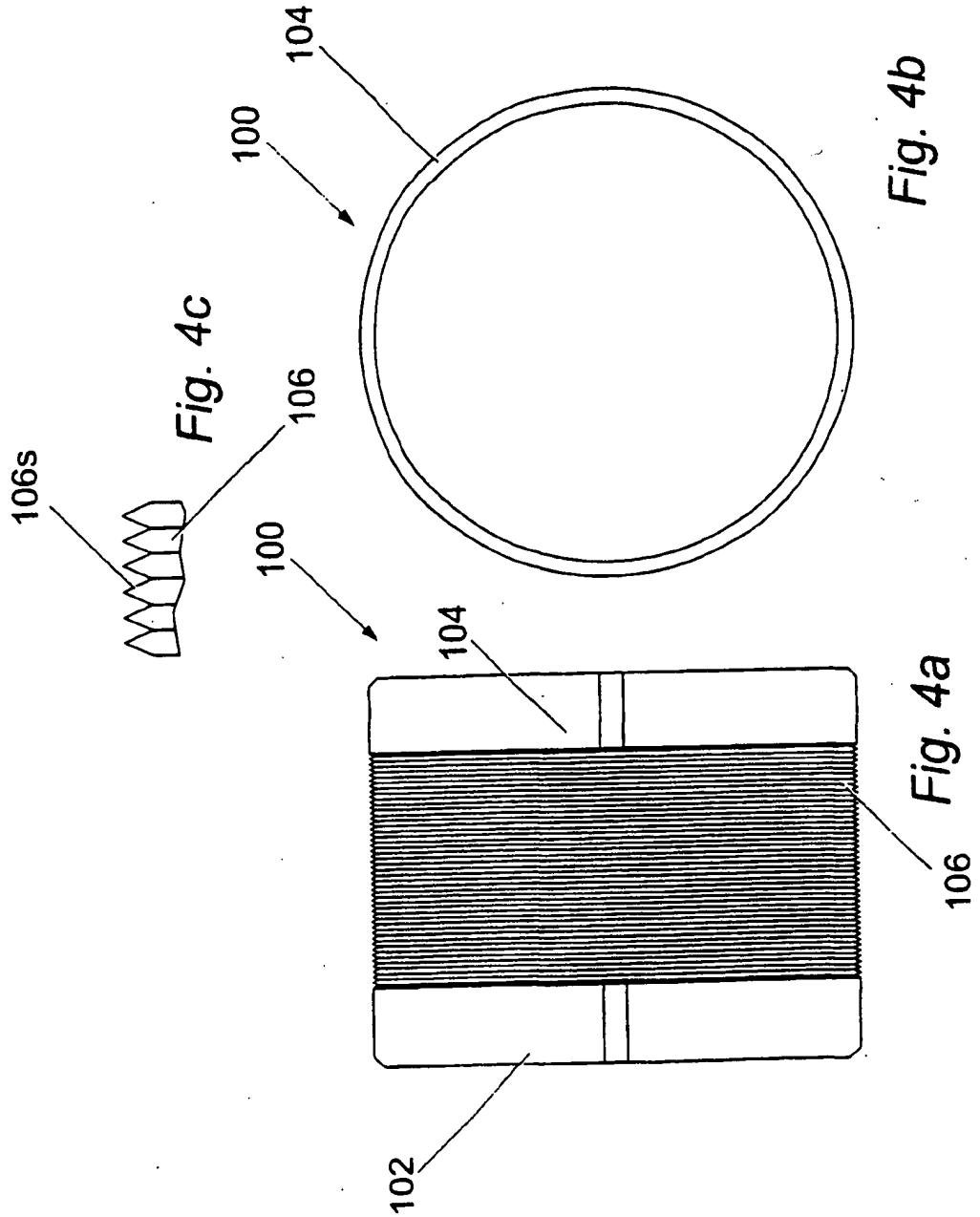

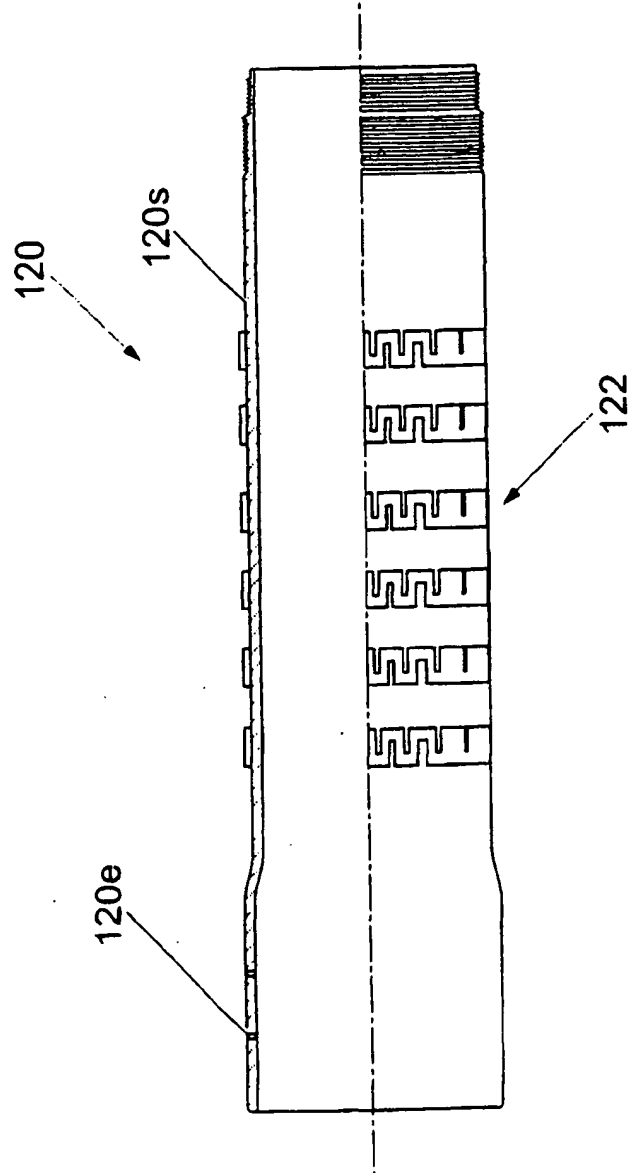

Fig. 5

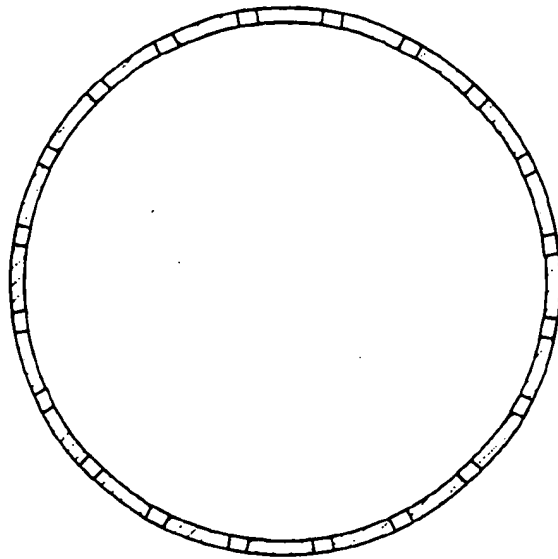

Fig. 6b

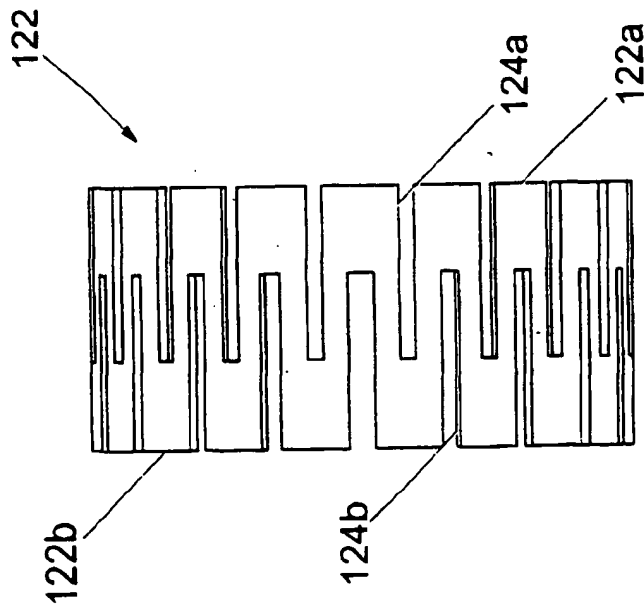

Fig. 6a

INTERNATIONAL SEARCH REPORT

Int. Application No
PCT/GB 00/03406

A. CLASSIFICATION OF SUBJECT MATTER
IPC 7 E21B43/10

According to International Patent Classification (IPC) or to both national classification and IPC

B. FIELDS SEARCHED

Minimum documentation searched (classification system followed by classification symbols)
IPC 7 E21B

Documentation searched other than minimum documentation to the extent that such documents are included in the fields searched

Electronic data base consulted during the international search (name of data base and, where practical, search terms used)

EPO-Internal

C. DOCUMENTS CONSIDERED TO BE RELEVANT

Category *	Citation of document, with indication, where appropriate, of the relevant passages	Relevant to claim No.
X	US 5 695 008 A (SALTEL JEAN-LOUIS ET AL) 9 December 1997 (1997-12-09) column 6, line 33 - line 43	1-5,7, 11,13, 16,18
X	EP 0 842 348 A (DRILLFLEX) 20 May 1998 (1998-05-20) the whole document	1-7,11, 13,16,18
A	WO 99 23354 A (METCALFE PAUL DAVID ;PETROLINE WELLSYSTEMS LTD (GB)) 14 May 1999 (1999-05-14) page 8, line 17 -page 9, line 3	1-19
P,A	GB 2 344 606 A (SHELL INT RESEARCH) 14 June 2000 (2000-06-14) abstract; figures 1-11	1-19

Further documents are listed in the continuation of box C.

Patent family members are listed in annex.

* Special categories of cited documents:

- *A* document defining the general state of the art which is not considered to be of particular relevance
- *E* earlier document but published on or after the international filing date
- *L* document which may throw doubts on priority claim(s) or which is cited to establish the publication date of another citation or other special reason (as specified)
- *O* document referring to an oral disclosure, use, exhibition or other means
- *P* document published prior to the international filing date but later than the priority date claimed

- *T* later document published after the international filing date or priority date and not in conflict with the application but cited to understand the principle or theory underlying the invention
- *X* document of particular relevance; the claimed invention cannot be considered novel or cannot be considered to involve an inventive step when the document is taken alone
- *Y* document of particular relevance; the claimed invention cannot be considered to involve an inventive step when the document is combined with one or more other such documents, such combination being obvious to a person skilled in the art.
- *S* document member of the same patent family

Date of the actual completion of the international search

17 November 2000

Date of mailing of the international search report

24/11/2000

Name and mailing address of the ISA

European Patent Office, P.B. 5816 Patentlaan 2
NL - 2280 HV Rijswijk
Tel. (+31-70) 340-2040. Tx. 31 651 epo nl.
Fax (+31-70) 340-3016

Authorized officer

Garrido Garcia, M

INTERNATIONAL SEARCH REPORT

Information on patent family members

International Application No

PCT/GB 00/03406

Patent document cited in search report	Publication date	Patent family member(s)	Publication date
US 5695008 A	09-12-1997	FR 2704898 A	10-11-1994
		AU 673261 B	31-10-1996
		AU 6660194 A	21-11-1994
		CA 2162035 A	10-11-1994
		CN 1122619 A, B	15-05-1996
		DE 69412252 D	10-09-1998
		DE 69412252 T	06-05-1999
		EP 0698136 A	28-02-1996
		WO 9425655 A	10-11-1994
		JP 8509532 T	08-10-1996
		NO 954299 A	07-12-1995
		RU 2123571 C	20-12-1998
EP 0842348 A	20-05-1998	FR 2737533 A	07-02-1997
		AT 194686 T	15-07-2000
		AU 696825 B	17-09-1998
		AU 6744196 A	05-03-1997
		DE 69609333 D	17-08-2000
		JP 11510229 T	07-09-1999
		NO 980428 A	03-04-1998
		US 6044906 A	04-04-2000
		CA 2228732 A	20-02-1997
		CN 1195389 A	07-10-1998
		WO 9706346 A	20-02-1997
		WO 9923354 A	14-05-1999
EP 1027526 A	16-08-2000		
NO 20001956 A	19-06-2000		
GB 2344606 A	14-06-2000	AU 5933599 A	08-06-2000
		BR 9906143 A	05-09-2000
		DE 19958399 A	13-07-2000
		NO 995991 A	08-06-2000